

# 3G3M1

## The Integrated Global Solution

- IM and PM motor control in OLV & CLV (200% torque at 0Hz).
- Multiple ratings: HHD 150%/1 min and HND 120%/1 min.
- 590 Hz max Output frequency
- Torque control for IM in OLV/CLV, PM in CLV.
- Speed, Position and Gear function.
- Flexible EtherCAT configuration: Standard and Ring topology.
- Built-in 1 encoder / pulse counter input.
- Safe Stop 0 (STO SIL3 PLe) wired and FSoE
- 24 VDC backup supply for control board.
- USB programming port.
- Program download without power supply
- Predictive maintenance drive parameters.
- Energy saving dedicated functionality.
- PC configuration tool: Sysmac Studio IDE
- Coated PCB for dust and moisture resistance.
- 10 years 24/7 Maintenance Free operation
- CE, UKCA, cULus, KC, RCM and RoHS.

### Ratings:

200 V Class single-phase 0.2 to 3.7 KW

200 V Class three-phase 0.2 to 18.5 KW

400 V Class three-phase 0.4 to 22 KW



## System configuration

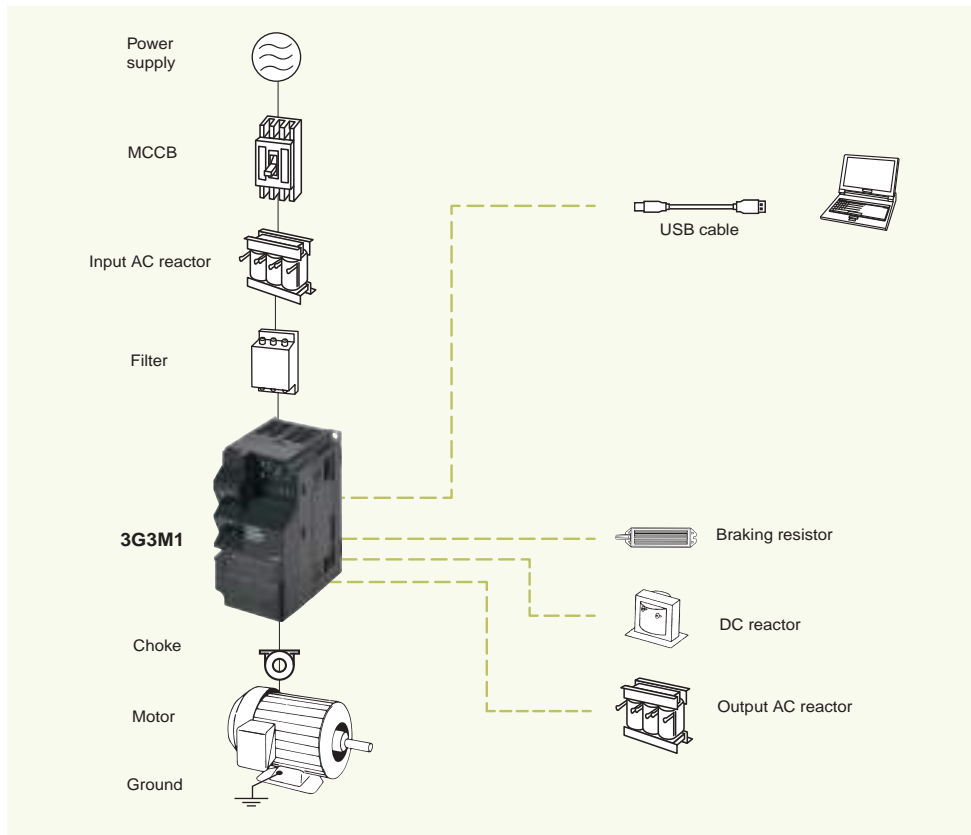

## Type designation

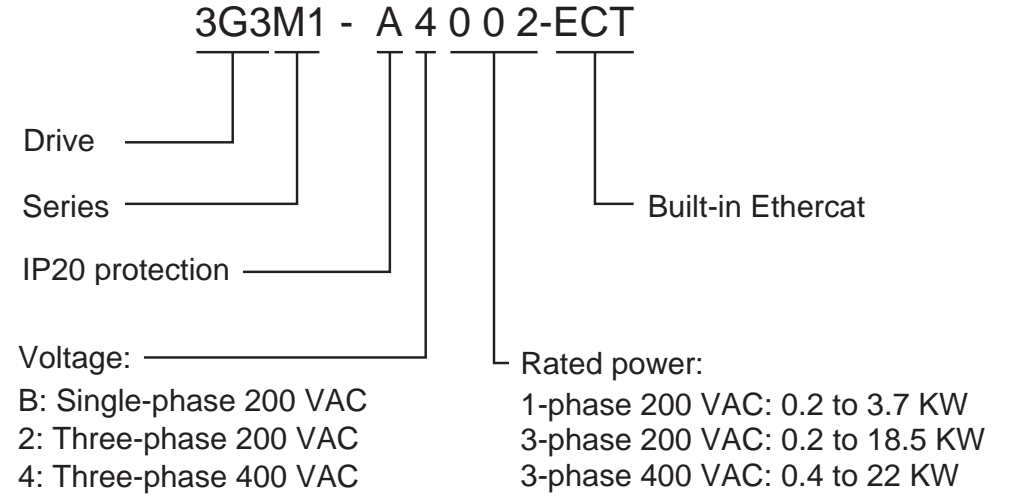

Single-phase 200 V: 3G3M1-A□-ECT		Duty rating	B002	B004	B007	B015	B022	B037
Max. applicable motor output (kW)		HHD	0.2	0.4	0.75	1.5	2.2	3.7
		HND	0.4	0.55	1.1	2	2.7	–
Output characteristics	Drive capacity (kVA) 200 V	HHD	0.6	1	1.7	2.8	3.8	6.1
		HND	0.7	1.2	2.1	3.3	4.2	–
	Drive capacity (kVA) 240 V	HHD	0.7	1.2	2.1	3.3	4.6	7.3
		HND	0.8	1.5	2.5	4	5	–
	Rated output current (A)	HHD	1.6	3	5	8	11	17.5
		HND	1.9	3.5 <sup>*1</sup>	6.0 <sup>*1</sup>	9.6 <sup>*1</sup>	12 <sup>*1</sup>	–
	Overload tolerance		HHD: 150% of the rated output current for 60 seconds or 200% 0.5s HND: 120% of the rated output current for 60 seconds					
	Carrier frequency (no-derating)		HND: 4 kHz HHD: 8kHz					
	Max. output voltage		Three-phase 200 to 240 V (with AVR)					
	Max. output frequency		590.0 Hz					
Power supply	Rated voltage and frequency		1-phase AC power supply 200-240 V at 50/60 Hz DC power supply 270-340 VDC					
	Allowable voltage fluctuation		–15% to +10%					
	Allowable frequency fluctuation		±5%					
	Rated Input current	HHD	3.3	5.4	9.7	16.4	22	45.4
		HND	4.9	7.3	13.8	20.2	26	–
	Rated Input current DC reactor	HHD	2.0	3.5	6.4	11.6	17.5	31.8
		HND	3.7	4.6	9.4	17.9	25.0	–
Rated power capacity	HHD	0.4	0.7	1.3	2.4	3.5	6.4	
	HND	0.8	1.0	1.9	3.6	5.5	–	
Braking	Natural deceleration braking torque (%) without resistor	HHD		100		70	40	40
		HND		73	68	48	29	–
	Minimum connectable resistor (Ohms)		40					
Weight (kg)			0.5	0.6	0.9	1.4	1.7	3.8

<sup>\*1</sup>. Values for 40°C ambient temperature

**Note:** “Applicable motor” represents standard three-phase motors. When using other types of motors, make sure that the rated current of the motor does not exceed that of the inverter.

Output voltage cannot exceed the power supply voltage.

For higher carrier frequency confirm with carrier derating tables in manual

The value is calculated assuming that the inverter is connected with a power supply with the capacity of 500 kVA (or 10 times the inverter capacity if the inverter capacity exceeds 50 kVA) and %X is 5%.

Three-phase 200 V: 3G3M1-A□-ECT		Duty rating	2002	2004	2007	2015	2022	2037	2055	2075	2110	2150	2185	
Max. applicable motor output (kW)	HHD	0.2	0.4	0.75	1.5	2.2	3.7	5.5	7.5	11	15	18.5		
	HND	0.4	0.75	1.1	2.2	3	5.5	7.5	11	15	18.5	22		
Output characteristics	Drive capacity (kVA) 200 V	HHD	0.6	1	1.7	2.8	3.8	6.1	8.7	11	16	21	26	
		HND	0.7	1.2	2.1	3.3	4.2	6.8	10	14	19	24	30	
	Drive capacity (kVA) 240 V	HHD	0.7	1.2	2.1	3.3	4.6	7.3	10	14	20	25	32	
		HND	0.8	1.5	2.5	4.0	5.0	8.1	12	17	23	29	37	
	Rated output current (A)	HHD	1.6	3	5	8	11	17.5	25	33	47	60	76	
		HND	2	3.5	6	9.6	12 <sup>*1</sup>	19.6 <sup>*1</sup>	30	40	56	69	88	
	Overload tolerance		HHD: 150% of the rated output current for 60 seconds or 200% 0.5s HND: 120% of the rated output current for 60 seconds											
	Carrier frequency (no-derating)		HHD: 8 kHz HND: 4 kHz							HHD: 10 kHz HND: 10 kHz				
	Max. output voltage		Three-phase 200 to 240 V (with AVR)											
	Max. output frequency		590.0 Hz											
Power supply	Rated voltage and frequency		3-phase AC power supply 200-240 V at 50/60 Hz DC power supply 270-340 VDC											
	Allowable voltage fluctuation		-15% to +10%											
	Allowable frequency fluctuation		±5%											
	Rated Input current	HHD	1.8	3.1	5.3	9.5	13.2	22.2	31.5	42.7	60.7	80	97	
		HND	2.6	4.9	6.7	12.8	17.9	28.5	42.7	60.7	80	97	112	
	Rated Input current DC reactor	HHD	0.93	1.6	3.0	5.7	8.3	14.0	21.1	28.8	42.2	57.6	71.0	
		HND	1.6	3.0	4.3	8.3	11.7	19.9	28.8	42.2	57.6	71.0	84.4	
Rated power capacity	HHD	0.4	0.6	1.1	2.0	2.9	4.9	7	10	15	20	25		
	HND	0.6	1.1	1.5	2.9	4.1	6.9	10	15	20	25	30		
Braking	Natural deceleration braking torque (%) without resistor		HHD	150		100	70	40	20					
	HND		75	53	68	48	29	27	15					
Minimum connectable resistor (Ohms)		100				40			33	20	15	10	8.6	4
Weight (kg)		0.5	0.6	0.8	1.4	1.4	1.7	3.8	4	5.3	5.4	11		

\*1. Values for 40°C ambient temperature

**Note:** "Applicable motor" represents standard three-phase motors. When using other types of motors, make sure that the rated current of the motor does not exceed that of the inverter.

Output voltage cannot exceed the power supply voltage.

For higher carrier frequency confirm with carrier derating tables in manual

The value is calculated assuming that the inverter is connected with a power supply with the capacity of 500 kVA (or 10 times the inverter capacity if the inverter capacity exceeds 50 kVA) and %X is 5%.

Three-phase 400 V: 3G3M1-A□-ECT		Duty rating	4004	4007	4015	4022	4030	4040	4055	4075	4110	4150	4185	4220	
Max. applicable motor output (kW)		HD	0.75	1.1	2.2	3	4	5.5	7.5	11	15	18.5	22	30	
		ND	0.75	1.5	2.2	3	4	5.5	11	15	18.5	22	30	37	
		HHD	0.4	0.75	1.5	2.2	3	4	5.5	7.5	11	15	18.5	22	
		HND	0.75	1.1	2.2	3 <sup>1</sup>	4	5.5 <sup>1</sup>	7.5	11	15	18.5	22	30	
Output characteristics	Drive capacity (kVA) 380 V		HD	1.2	2.2	3.3	4.1	5.8	7.3	12	15	20	25	30	39
			ND	1.4	2.7	3.6	4.5	6.1	7.9	14	19	24	29	39	47
			HHD	1.2	2.2	3.2	3.6	4.7	6.1	9.7	12	16	20	26	30
			HND	1.4	2.7	3.6	4.5	5.8	7.3	12	15	20	25	30	39
	Drive capacity (kVA) 480 V		HD	1.5	2.8	4.2	5.2	7.3	9.2	15	19	26	32	37	50
			ND	1.7	3.4	4.6	5.7	7.6	10	18	24	31	37	49	60
			HHD	1.5	2.8	4	4.6	6	7.6	12.3	15	20	26	32	37
			HND	1.7	3.4	4.6	5.7	7.3	9.2	15	19	26	32	37	50
	Rated output current (A)		HD	1.8	3.4	5.0	6.3	8.8	11.1	17.5	23	31	38	45	60
			ND	2.1	4.1	5.5	6.9	9.2	12	21.5	28.5	37	44	59	72
			HHD	1.8	3.4	4.8	5.5	7.2	9.2	14.8	18	24	31	39	45
			HND	2.1	4.1	5.5	6.9	8.8	11.1	17.5	23	31	38	45	60
	Overload tolerance			HHD: 150% of the rated output current for 60 seconds or 200% 0.5s HD: 150% of the rated output current for 60 seconds HND/ND: 120% of the rated output current for 60 seconds											
	Carrier frequency (no-derating)			HHD/HND: 8 kHz HD/ND: 4 kHz						HHD/HND: 10 kHz HD/ND: 4 kHz					
	Max. output voltage			Proportional to input voltage: 380-480 V											
	Max. output frequency			590 Hz											

Three-phase 400 V: 3G3M1-A□-ECT		Duty rating	4004	4007	4015	4022	4030	4040	4055	4075	4110	4150	4185	4220
Power supply	Rated voltage and frequency	3-phase AC power supply 380-480 V at 50/60 Hz												
	Allowable voltage fluctuation	-15% to +10%												
	Allowable frequency fluctuation	±5%												
	Rated Input current	HD	2.7	3.9	7.3	11.3	14.2	16.8	23.2	33.0	43.8	52.3	60.6	77.9
		ND	2.7	4.8	7.3	11.3	14.2	16.8	33.0	43.8	52.3	60.6	77.9	94.3
		HHD	1.7	3.1	5.9	8.2	11.3	14.2	17.3	23.2	33.0	43.8	52.3	60.6
		HND	2.7	3.9	7.3	11.3	14.2	16.8	23.2	33.0	43.8	52.3	60.6	77.9
	Rated Input current DC reactor	HD	1.5	2.1	4.2	5.8	7.7	10.1	14.4	21.1	28.8	35.5	42.2	57.0
		ND	1.5	2.9	4.2	5.8	7.7	10.1	21.1	28.8	35.5	42.2	57.0	68.5
		HHD	0.85	1.6	3.0	4.4	5.8	7.7	10.6	14.4	21.1	28.8	35.5	42.2
		HND	1.5	2.1	4.2	5.8	7.7	10.1	14.4	21.1	28.8	35.5	42.2	57.0
	Required power capacity	HD	1.1	1.5	3.0	4.1	5.4	7.0	10	15	20	25	29	39
		ND	1.1	2.1	3.0	4.1	5.4	7.0	15	20	25	29	39	47
		HHD	0.6	1.2	2.1	3.1	4.1	5.4	7.3	10	15	20	25	29
HND		1.1	1.5	3.0	4.1	5.4	7.0	10	15	20	25	29	39	
Braking	Natural deceleration braking torque (%) without resistor	HD	53	68	48	29	29	27	15					
		ND	53	50	48	29	29	27	12					
		HHD	100		70	40	40	40	20					
		HND	53	68	48	29	29	27	15					
Minimum connectable resistor (Ohms)		200		160		130		80	60	40	34.4	16		
Weight (kg)		1.2	1.4	1.5	1.4	1.8	1.8	3.7	3.8	5.3	5.4	11	11	

\*1: Values for 40°C ambient temperature

**Note:** "Applicable motor" represents standard three-phase motors. When using other types of motors, make sure that the rated current of the motor does not exceed that of the inverter.

Output voltage cannot exceed the power supply voltage.

For higher carrier frequency confirm with carrier derating tables in manual

The value is calculated assuming that the inverter is connected with a power supply with the capacity of 500 kVA (or 10 times the inverter capacity if the inverter capacity exceeds 50 kVA) and %X is 5%.

## Common specifications

Model number 3G3M1-A□-ECT		Specifications
Control functions	Control methods	V/f, Dynamic torque vector and vector control with and without feedback.
	Motor support	Asynchronous Induction motor Permanent Magnet synchronous motor (Only Vector control with and without feedback)
	Frequency control range	0.00 to 590.0 Hz
	Frequency tolerance	Digital inputs: $\pm 0.01\%$ of the max. output frequency Analog inputs: $\pm 0.2\%$ of the max. output frequency ( $25 \pm 10$ °C)
	Frequency setting resolution	Digital inputs: 0.01 Hz Analog inputs: Maximum frequency $\times 5/10,000$ Communication setting: 0.005% of the maximum output frequency or 0.01 Hz (fixed)
	Output frequency resolution	0.001 Hz
	Frequency setting signal	Main speed freq reference: $-10$ to $10$ VDC ( $22$ k $\Omega$ )
	Starting torque	V/f: 150%/10% of rated speed 200% /0.5Hz Vector without sensor or V/f with feedback 200%/0.0 Hz Vector with feedback
	Speed control range	1:100 V/f mode 1:200 Dynamic torque vector without feedback / vector without feedback / V/f with feedback 1:500 Dynamic torque vector with feedback 1:1500 Vector control with feedback
	Zero speed control	Vector with feedback
	Torque limits	4 quadrant and 4 independent settings
Accel/Decel Time	0.00 to 6000s (the drive can set two pairs of different acceleration and deceleration times)	
Functionality	Protective functions	Overcurrent, Overvoltage, Undervoltage, Electronic thermal, Temperature error, Ground-fault current at power-on, Rush current prevention circuit, Overload limit, Incoming overvoltage, External trip, Memory error, CPU error, USP error, Communication error, Overvoltage suppression during deceleration, Power interruption protection, Emergency shutoff, etc.
	Main control functions	Torque boost, AVR control, Energy saving, Motor sound, slip compensation, DC injection, Frequency auto-search, current limiter, ASR control, zero speed control servo lock, heavy deceleration brake, pre-excitation, Positioning, Master-Slave follower, overload stop, second motor, brake control,
Environment	Operation ambient temperature	$-10$ to $50$ °C (Derating required)
	Storage ambient temperature	$-25$ to $70$ °C (Short-time temperature during shipment)
	Operating ambient humidity	5 to 95% (with no condensation)
	Vibration resistance	Vibration Frequency Specification 2 to 9 Hz à 3 mm (0.12 inch) (Max. amplitude) 9 to 20 Hz à 1 G 20 to 55 Hz à 0.2 G 55 to 200 Hz à 0.1 G
	Location	Maximum altitude of 1,000 m, indoors (without corrosive gases or dust). From 1,000 to 3,000 a derating of 0,6% every 100m should be applied.

Model number 3G3M1-A□-ECT		Specifications	
Regulations and Standards	CE UKCA	EMC	EN 61800-3:2004/A1:2012 (2018 is ratified)
		Functional safety	IEC 61800-5-2:2016 IEC/EN 61800-5-2:2017 STO SIL3 EN ISO 13849-1:2015, Cat.3 / Ple (2016 already exist)
		Electrical safety	EN 61800-5-1:2017
	UL	US	UL61800-5-1, Edition 1, 2012 (A1 2017 ratified)
		CA	CSA-C22.2 No.274, 2017
	KC		KS-C9800-3 (Pending)
	EAC		–
	RCM		EN 61800-3:2004+A1:2012 (2016 ratified)
Protection design		Open chassis type: IP20	



# Dimensions

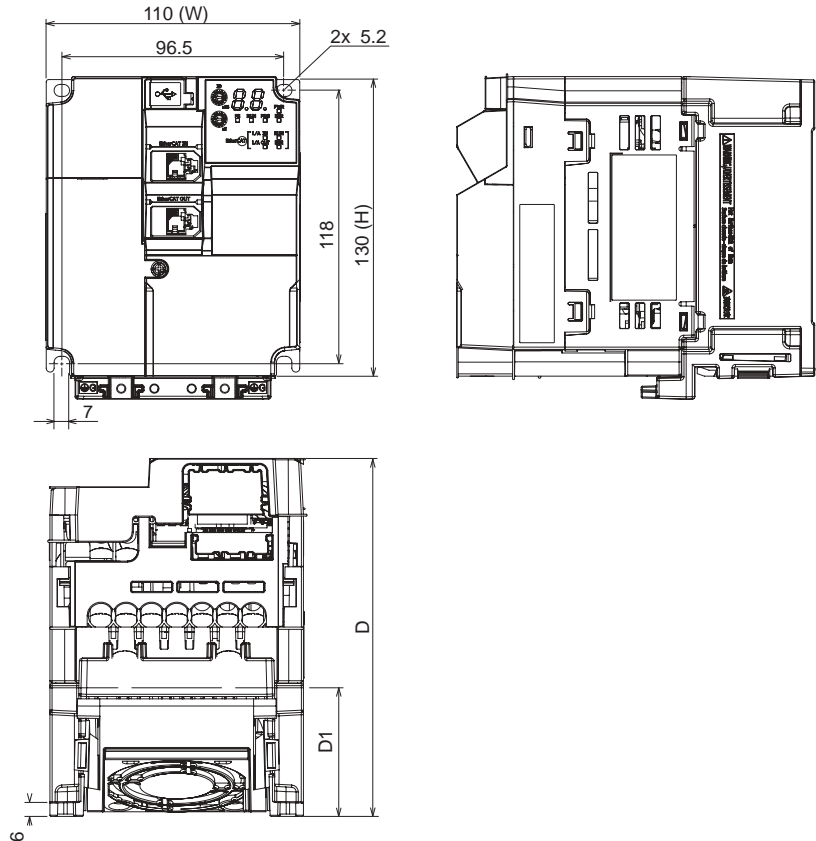
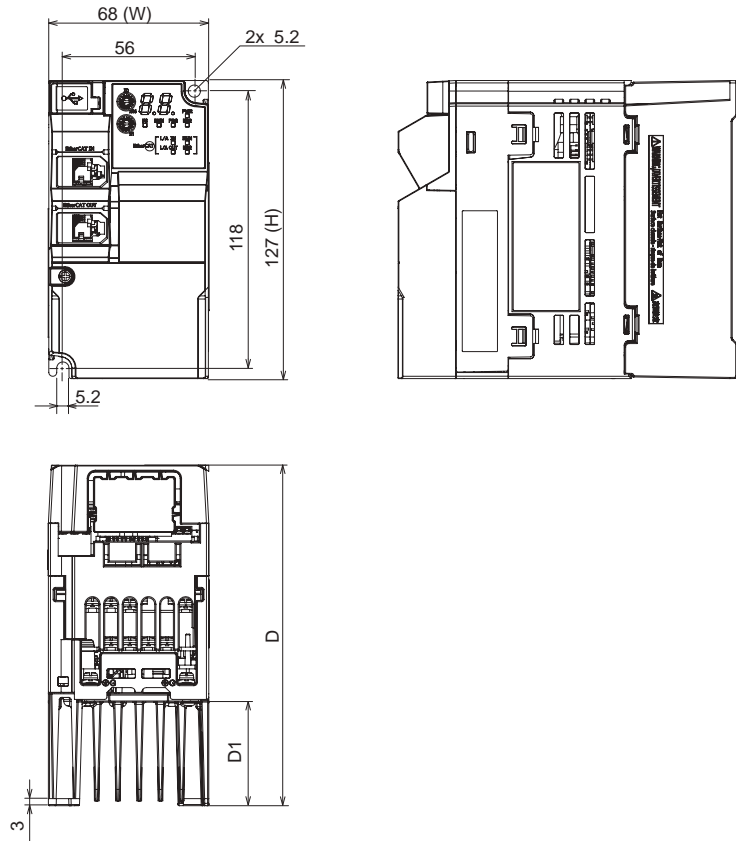

Power Supply	Model	W (mm)	H (mm)	D (mm)	D1 (mm)
Single-phase 200 V	3G3M1-AB002-ECT	68	127	98	8
	3G3M1-AB004-ECT			120	23
	3G3M1-AB007-ECT			165	48
Three-phase 200 V	3G3M1-A2002-ECT	68	127	98	8
	3G3M1-A2004-ECT			113	23
	3G3M1-A2007-ECT			145	48

Power supply	Model	W (mm)	H (mm)	D (mm)	D1 (mm)
Single-phase 200 V	3G3M1-AB015-ECT	110	130	166	58
Three-phase 200 V	3G3M1-A2015-ECT			156	
	3G3M1-A2022-ECT			132	38
Three-phase 400 V	3G3M1-A4004-ECT	110	130	156	58
	3G3M1-A4007-ECT				
	3G3M1-A4015-ECT				
	3G3M1-A4022-ECT				

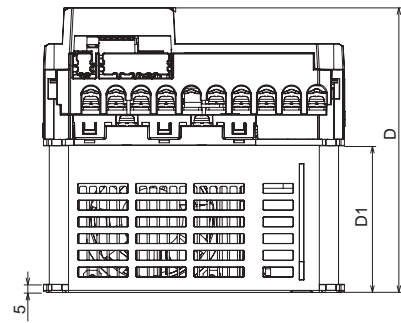
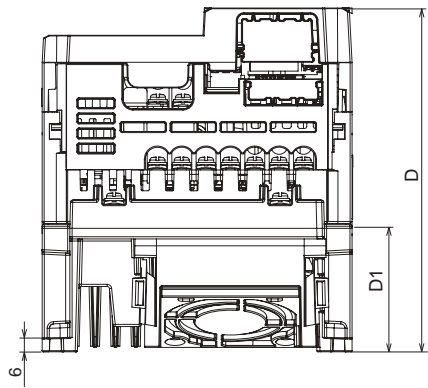
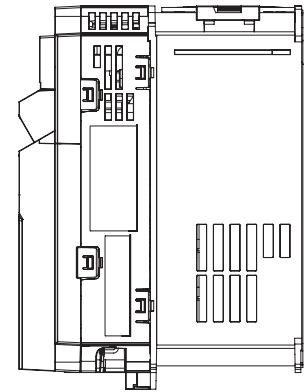
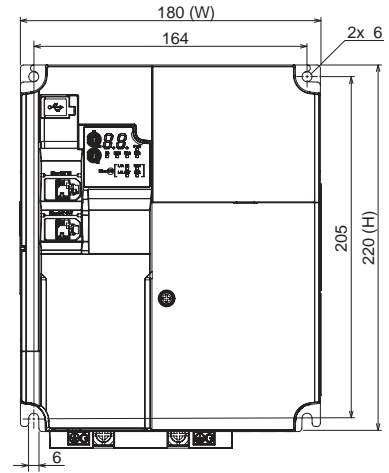
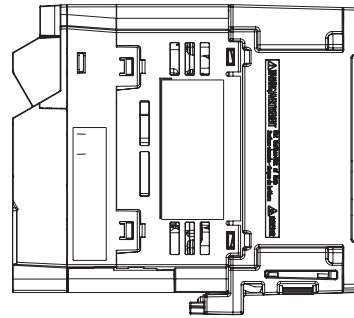
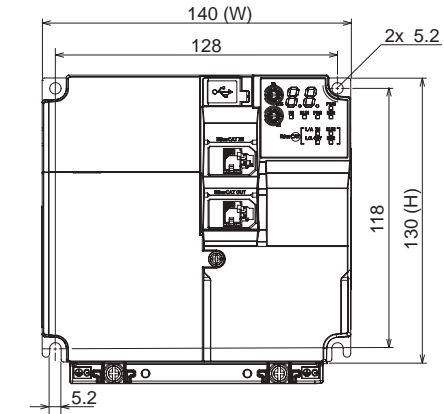

Power supply	Model	W (mm)	H (mm)	D (mm)	D1 (mm)
Single-phase 200 V	3G3M1-AB022-ECT	140	130	156	58
Three-phase 200 V	3G3M1-A2037-ECT				
Three-phase 400V	3G3M1-A4030-ECT				
	3G3M1-A4040-ECT				

Power supply	Model	W (mm)	H (mm)	D (mm)	D1 (mm)
Single-phase 200 V	3G3M1-AB037-ECT	180	220	171	87.7
Three-phase 200 V	3G3M1-A2055-ECT				
	3G3M1-A2075-ECT				
Three-phase 400 V	3G3M1-A4055-ECT				
	3G3M1-A4075-ECT				

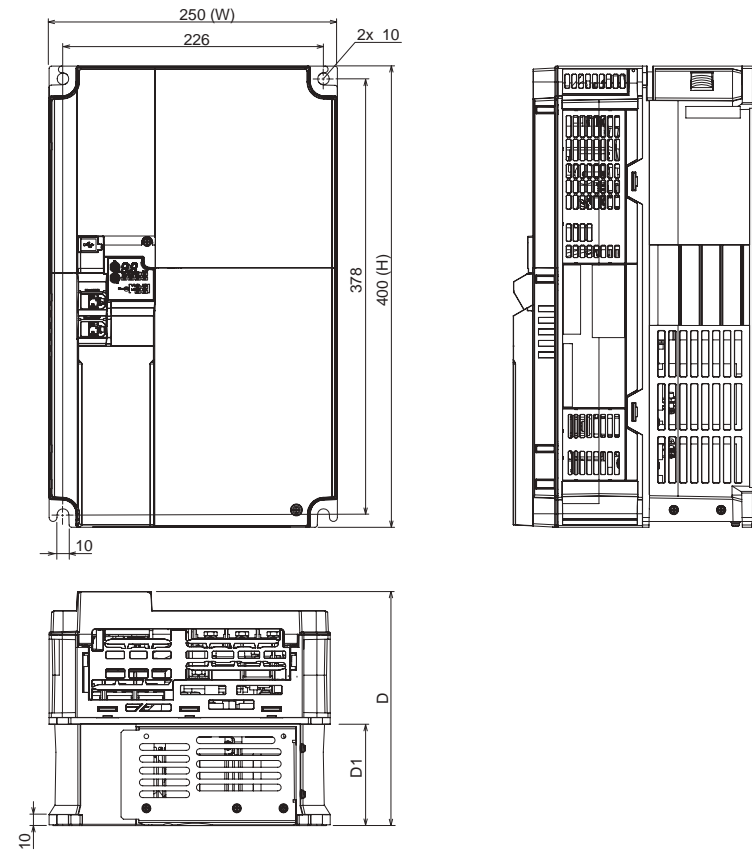
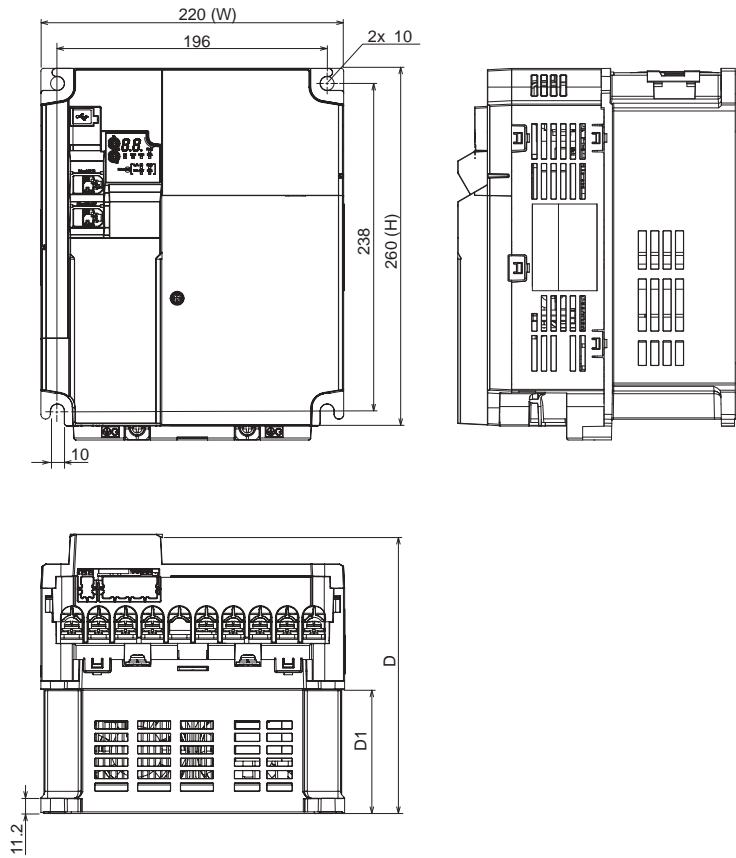

Power supply	Model	W (mm)	H (mm)	D (mm)	D1 (mm)
Three-phase 200 V	3G3M1-A2110-ECT	220	260	203	90
	3G3M1-A2150-ECT				
Three-phase 400 V	3G3M1-A4110-ECT				
	3G3M1-A4150-ECT				

Power supply	Model	W (mm)	H (mm)	D (mm)	D1 (mm)
Three-phase 200 V	3G3M1-A2185-ECT	250	400	203	90
Three-phase 400 V	3G3M1-A4185-ECT				
	3G3M1-A4220-ECT				

Line filters  
AX-FIC1014-SE

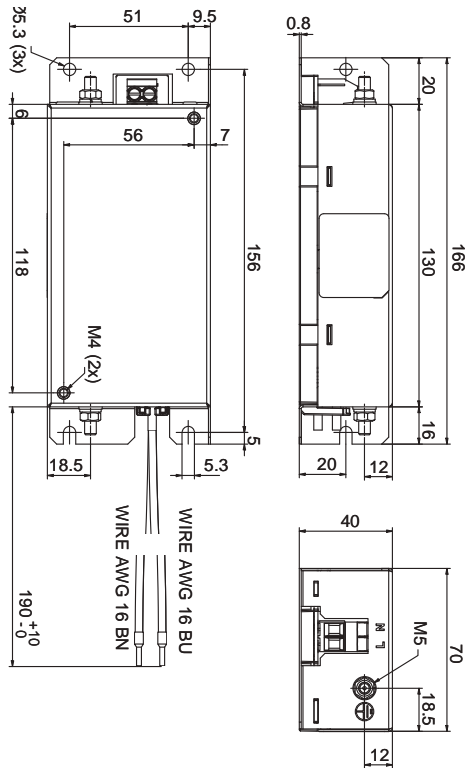

AX-FIC1021-SE

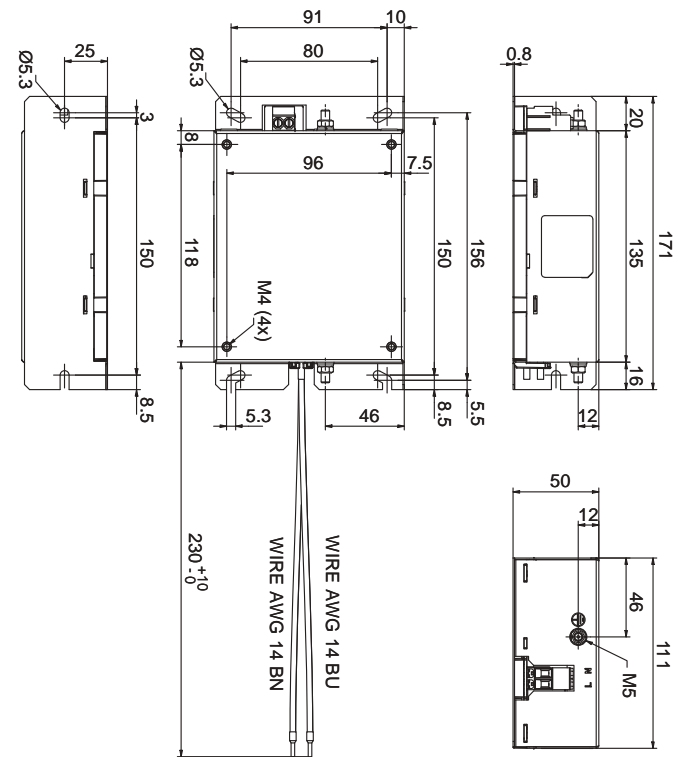

AX-FIC1026-SE

AX-FIC1045-SE

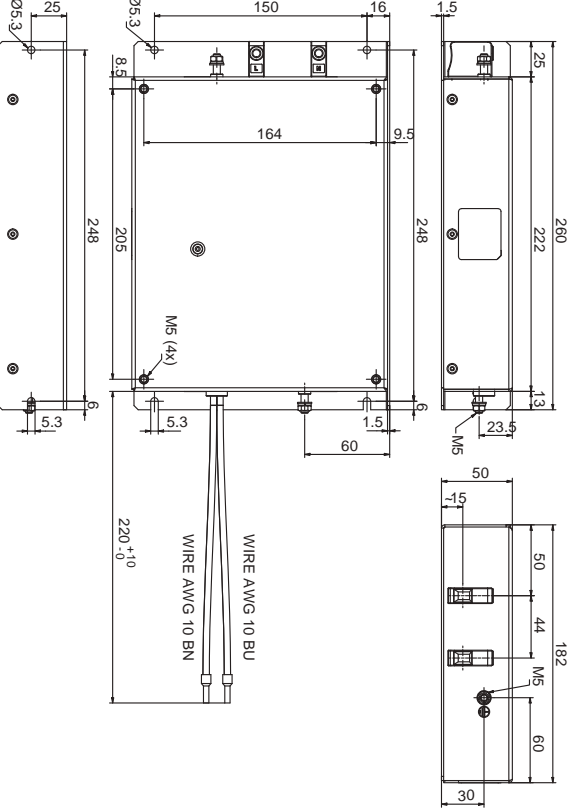
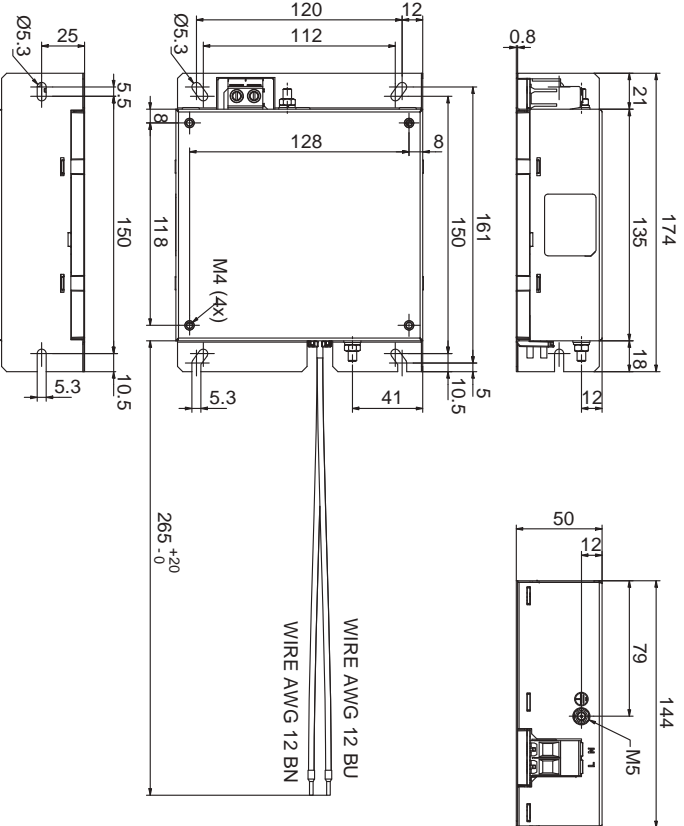

AX-FIC4004-SE

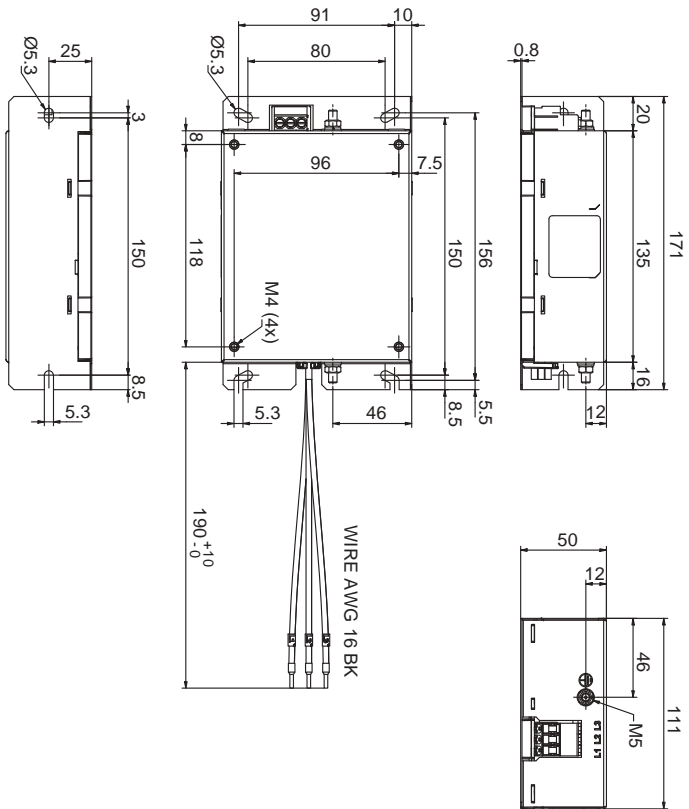

AX-FIC4011-SE

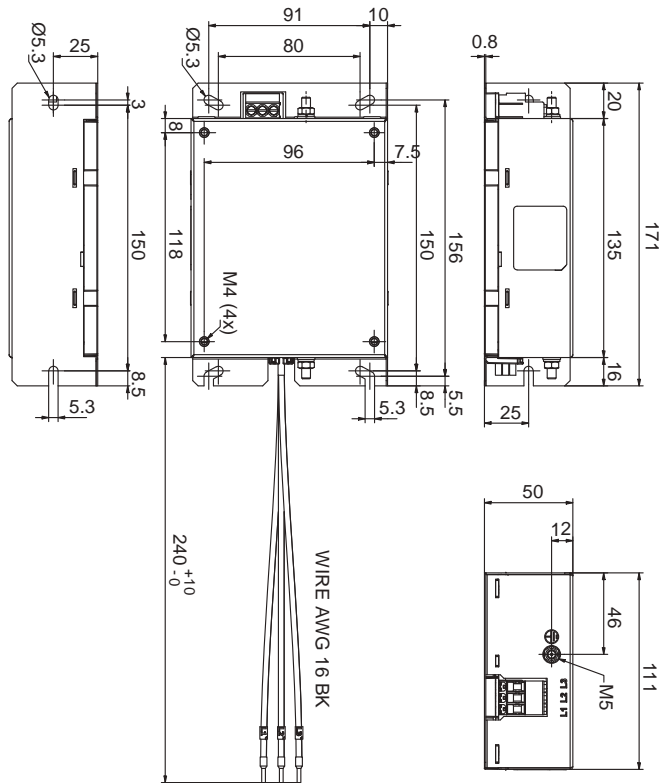

AX-FIC4017-SE

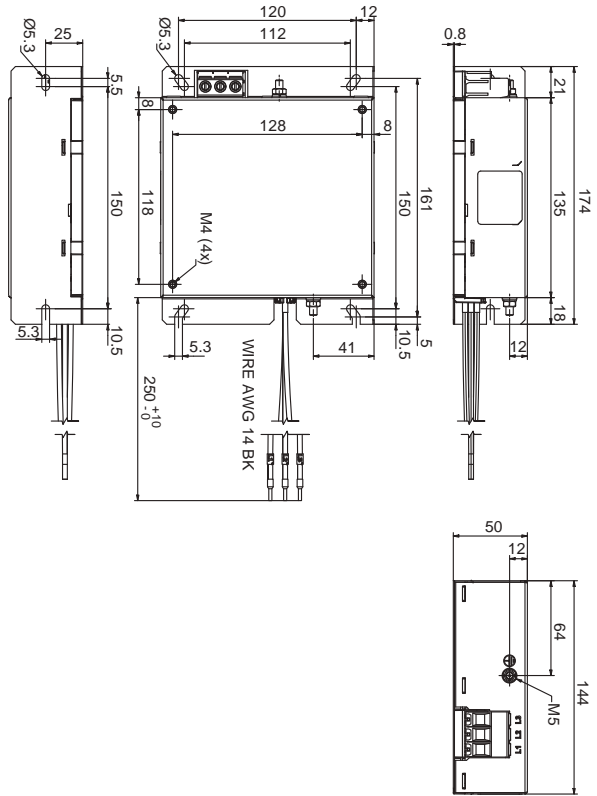

AX-FIC4044-SE

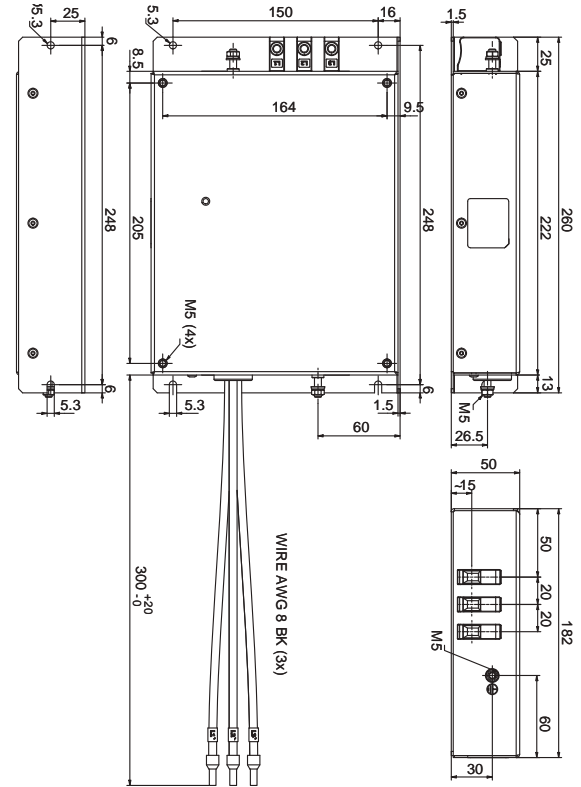

AX-FIC4061-SE

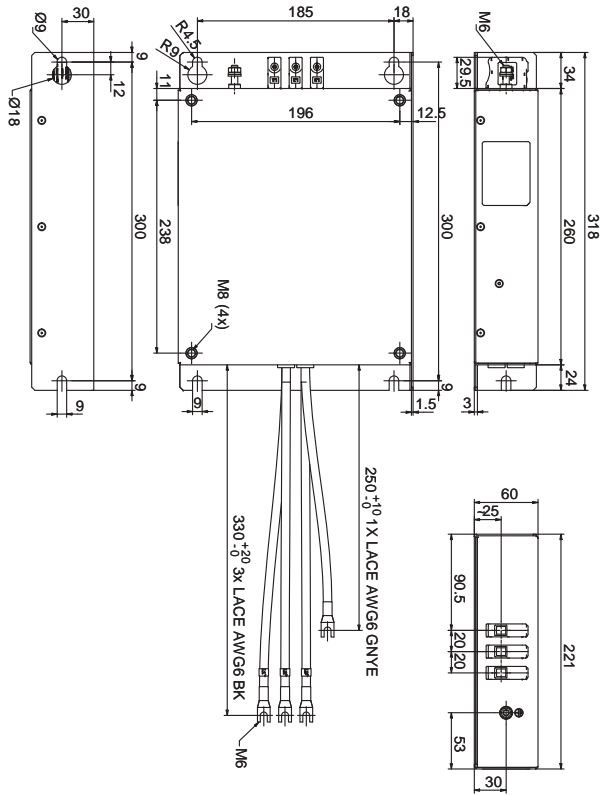

AX-FIC4095-SE

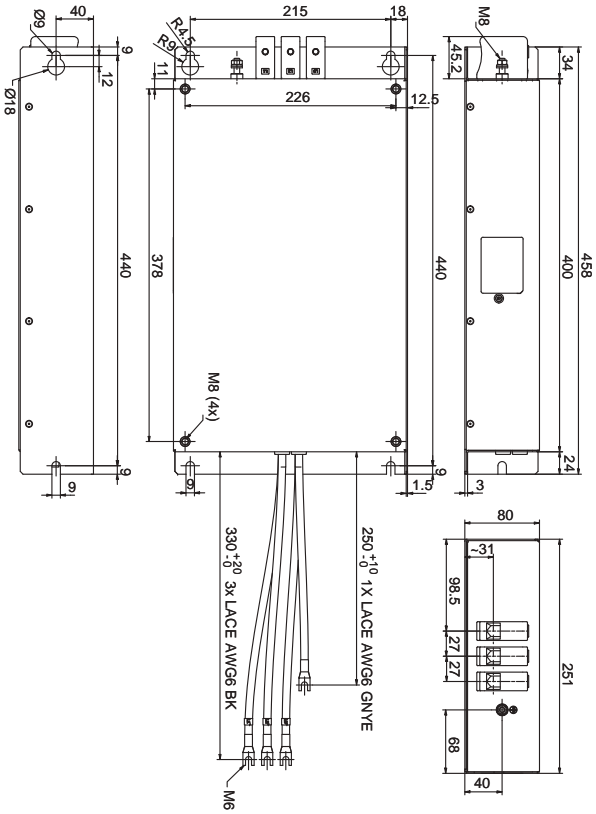



Input AC Reactor

Voltage	Reference	Fig	Dimensions (mm)										Weight (kg)												
			A	B	B2	C	C2	D	E	F	G	H													
Single-phase 200 V	AX-RAI02000070-DE	1	84	113	-	96	-	101	66	5	7.5	2	1.22												
	AX-RAI01700140-DE					116							1.95												
	AX-RAI01200200-DE					131							2.55												
	AX-RAI00630240-DE												1.95												
	AX-RAI00210330-DE												2.35												
Three-phase 200 V	AX-RAI02920030-DE	2	120	70	-	80	120	80	52	5.5	-	-	1.78												
	AX-RAI01570050-DE					116																			
	AX-RAI00940080-DE																								
	AX-RAI00670110-DE																								
	AX-RAI00450170-DE																								
	AX-RAI00290250-DE																								
	AX-RAI00210330-DE																								
	AX-RAI00180670-DE					80								62	2.35										
	AX-RAI00110600-DE					180								85	190	140	55	6	5.5						
	AX-RAI00076870-DE														205				6.5						
	AX-RAI00091000-DE																								
	Three-phase 400 V					AX-RAI07700042-DE								2	120	70	-		120	80	52	5.5	-	-	1.78
						AX-RAI03700040-DE																			
AX-RAI02800080-DE																									
AX-RAI01630090-DE																									
AX-RAI01300170-DE		180	75	195	140	55	6	5.5																	
AX-RAI00810180-DE		120	80	120	80	62	5.5	2.35																	
AX-RAI00740335-DE		180	85	190	140	55	6	5.5																	
AX-RAI00440300-DE																									
AX-RAI00300450-DE																									
AX-RAI00360500-DE																									
AX-RAI00290780-DE		105	205	75	11.2																				
AX-RAI00191150-DE	240	110	275			200	16.0																		

Figure 1

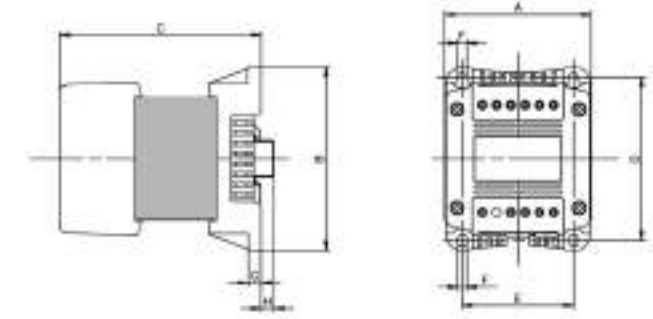
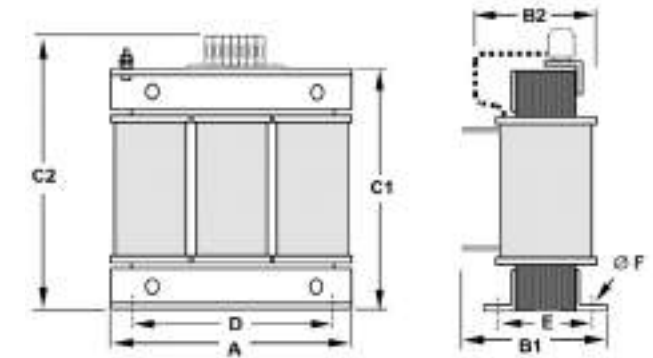

Figure 2



DC Reactor

Voltage	Reference	Fig	Dimensions (mm)								Weight	
			A	B	C	D	E	F	G	H		
200 V	AX-RC21400016-DE	1	84	113	96	101	66	5	7.5	2	1.22	
	AX-RC10700032-DE				105						1.60	
	AX-RC06750061-DE				116						1.95	
	AX-RC02510138-DE		108	135	124	120	82	6.5	9.5	9.5	3.20	
	AX-RC01600223-DE		120	152	136	135	94	7			5.20	
	AX-RC01110309-DE		150	177	146		160		115	2	-	6.00
	AX-RC00840437-DE				183	11.40						
	AX-RC00590614-DE		2	195	161	163	185	88	10	-	-	14.30
	AX-RC00440859-DE											17
	AX-RC00301275-DE											
	400 V	AX-RC43000020-DE	1	84	113	96	101	66	5	7.5	2	1.22
AX-RC27000030-DE		105				1.60						
AX-REC14000047-DE		116				1.95						
AX-RC10100069-DE		108		135	133	120	82	6.5	9.5	9.5	3.70	
AX-RC06400116-DE		120		152	136	135	94	7			5.20	
AX-RC04410167-DE		150		177	146		160		115	2	-	6.00
AX-RC03350219-DE					183	11.4						
AX-RC02330307-DE		2		195	161	163	185	88	10	-	-	14.3
AX-RC01750430-DE												196
AX-RC01200644-DE												
AX-RC00920797-DE												

Figure 1

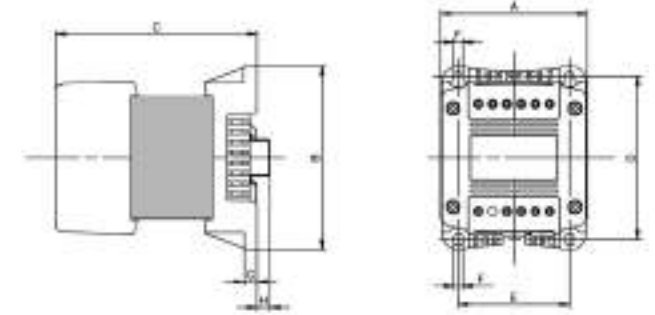
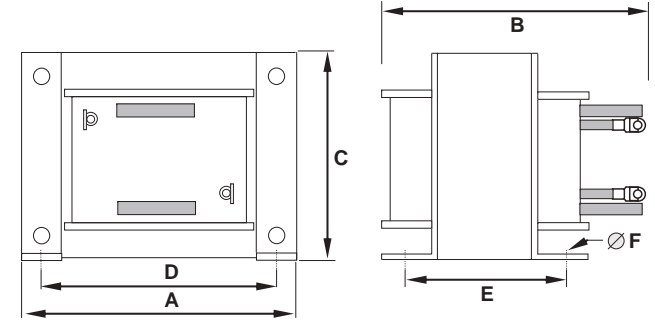
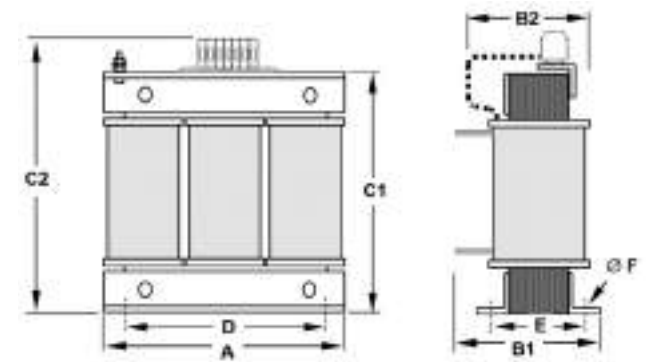

Figure 2



Output AC Reactor

Voltage	Reference	Dimensions (mm)						Weight (kg)
		A	B2	C2	D	E	F	
200 V	AX-RAO11500026-DE	120	70	120	80	52	5.5	1.78
	AX-RAO07600042-DE		80			62		2.35
	AX-RAO04100075-DE							
	AX-RAO03000105-DE							
	AX-RAO01830160-DE	180	85	195	140	55	6	5.5
	AX-RAO01150220-DE					95		210
	AX-RAO00950320-DE		105	75	11.7			
	AX-RAO00630430-DE							
	AX-RAO00490640-DE	240	110	275	200	75	6	16.0
	AX-RAO00390800-DE							
AX-RAO00330950-DE								
400 V	AX-RAO16300038-DE	120	80	120	80	62	5.5	2.35
	AX-RAO11800053-DE							
	AX-RAO07300080-DE	180	85	195	140	55	6	5.5
	AX-RAO04600110-DE							
	AX-RAO03600160-DE							
	AX-RAO02500220-DE							
	AX-RAO02000320-DE	240	110	275	200	75	6	16.0
	AX-RAO01650400-DE							
AX-RAO01300480-DE								
AX-RAO00800750-DE								



Chokes

Reference	D (diameter)	Motor (kW)	Dimensions (mm)							Weight (Kg)	
			A	B	C	D	E	F	G (diameter)		
AX-FER2102-PE	21	< 2.2	86	24	50	21	70	12	4	0.09	
AX-FER2815-PE	28	< 15	106	25	65	28	90	12.5		0.22	
AX-FER5045-PE	50	< 45	150	51	112	50	125	30	5	0.53	

Braking resistor

Fig. 1

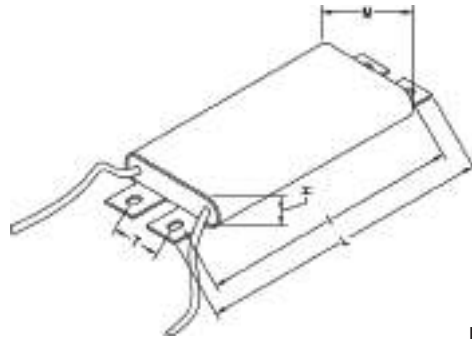

Fig. 2

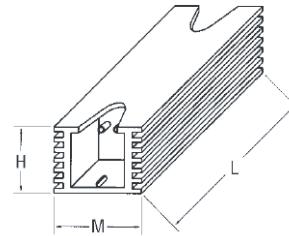

Fig. 3



Fig. 4

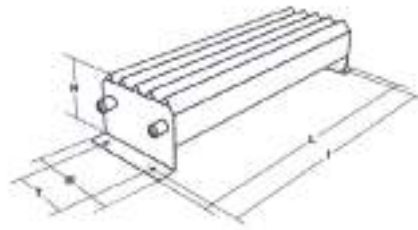

Fig. 5



Type	Fig	Dimensions (mm)							Weight (kg)
		L	H	M	I	T	G	N	
AX-REM00K1xxx-IE	1	182	13	45	168	20			0.27
AX-REM00K2xxx-IE	2	105	27	36	94	-			0.17
AX-REM00K3xxx-IE		155			144				0.26
AX-REM00K4xxx-IE		200			189				0.425
AX-REM00K6xxx-IE		320			309				0.73
AX-REM00K9xxx-IE	3	200	61	100	74.5	216	40	230	1.41
AX-REM01K1xxx-IE		260			276	290		1.83	
AX-REM01K3xxx-IE		320			336	350		2.25	
AX-REM01K9xxx-IE	4	365	73	105	350	70			4
AX-REM02K1xxx-IE	5	310	115	230	295	170	-		7
AX-REM03K5xxx-IE		365			350				8

# Installation

## Standard connections

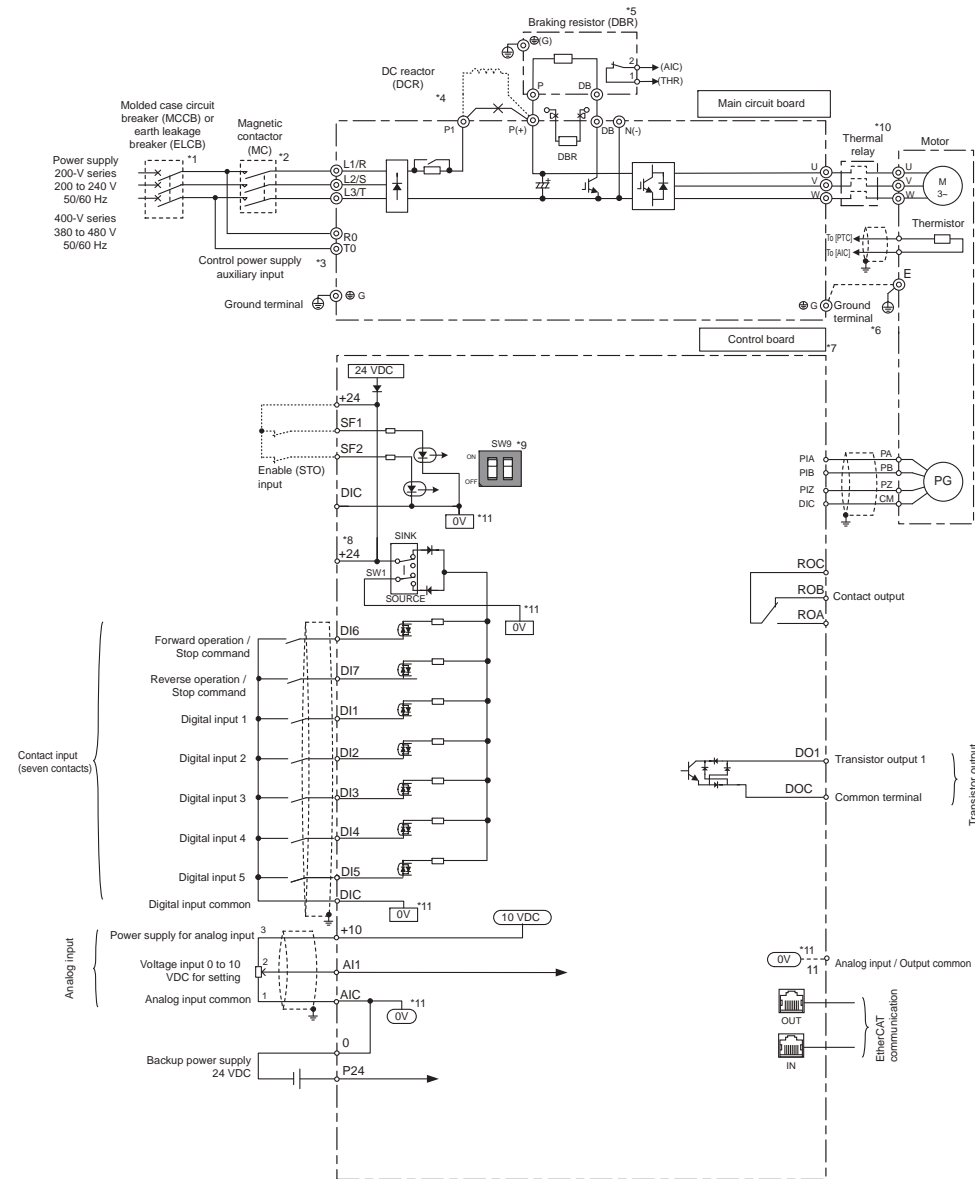

## Main circuit

Terminal	Name	Function
L1/R, L2/S, L3/T	Main supply terminals (3G3M1-A2 and 3G3M1-A4)	Used to connect a power supply
L1/L, L2/N	Main circuit power supply input (3G3M1-AB_)	Used to connect a power supply
U, V, W	Inverter output terminal	Used to connect a motor
P(+), DB	Braking resistor connection	To connect a braking resistor
P1, P(+)	DC reactor connection	Remove the short-circuit to connect the optional DC reactor
P(+), N(-)	Regenerative braking unit connection terminal	Connect optional regenerative braking unit if braking torque produced by internal braking transistor is not enough
R0, T0	Control power supply auxiliary input	Only available for inverter size of 18 KW or more. Helps to keep control signal, digital operator or communications alive while main supply is off. 3G3M1-A2185: Single-phase 200 to 240 V, 50/60Hz 3G3M1-A4185/220: Single-phase 220 to 480 V, 50/60Hz
⊕ G	Ground terminal	Connect the terminal to ground.

## Control circuit

Type	Terminal	Name	Function (Signal level)
Digital input signals	DI1	Multi-Function Digital Input 1 (Multi-speed 1)	Voltage levels between input and the DIC: ON voltage: 20 V min OFF voltage 2 V max  Maximum 27 VDC  Load current (DI1, DI2): 2.5 to 16 mA (at 27 V) Load current (DI3 to DI7): 2.5 to 5 mA (at 27 V)  Impedance: 5.4 kΩ
	DI2	Multi-Function Digital Input 2 (Multi-speed 2)	
	DI3	Multi-Function Digital Input 3 (Multi-speed 3)	
	DI4	Multi-Function Digital Input 4 (Free run stop)	
	DI5	Multi-Function Digital Input 5 (Reset)	
	DI6	Multi-Function Digital Input 6 (Forward)	
	DI7	Multi-Function Digital Input 7 (Reverse)	
	DIC	Input Signal common	
Safety digital inputs	SF1	Safe input 1	Voltage levels between input and the DIC ON voltage: 20 V min OFF voltage: 2 V max Maximum 27 VDC Load current: 2.5 to 5 mA (at 27 V) Impedance: 6.6 kΩ
	SF2	Safe input 2	
Pulse	PIA	Pulse and encoder input	Voltage between input and DIC (5 to 24 VDC) ON voltage: 4 V min OFF voltage: 2 V max Maximum 27 VDC Frequency: 32 KHz max Impedance: : 7.2 kΩ
	PIB		
	PIZ		

Type	Terminal	Name	Function (Signal level)
Analog input signals	+10	Power supply for analog input	Max current: 10 mA
	AI1	Analog voltage input	Allowable input voltage range: -15 to 10 VDC Impedance: 22 kΩ
	AIC	Analog input common	
	PTC	External thermistor input	Thermistor between the PTC and the AIC.
Fault relay output	ROA	Relay output terminal NO	Relay output 250 VAC, 0,3 A 48 VDC, 0.5 A
	ROB	Relay output terminal NC	
	ROC	Relay output common	
Multi-function photocoupler outputs	DO1	Multi-Function Photocoupler Output 1 (During Run)	Open collector output across DO1-DOC Max Voltage 48 VDC and 50 mA
	DOC	Output signal common	
Power supply	+24	Power supply terminal	Max 100 mA
	P24	Auxiliary power supply input for control circuit. P24 terminal is insulated from +24 terminal	24 VDC (22 to 26 V) and 500 mA max.
	0		

Side by side mounting

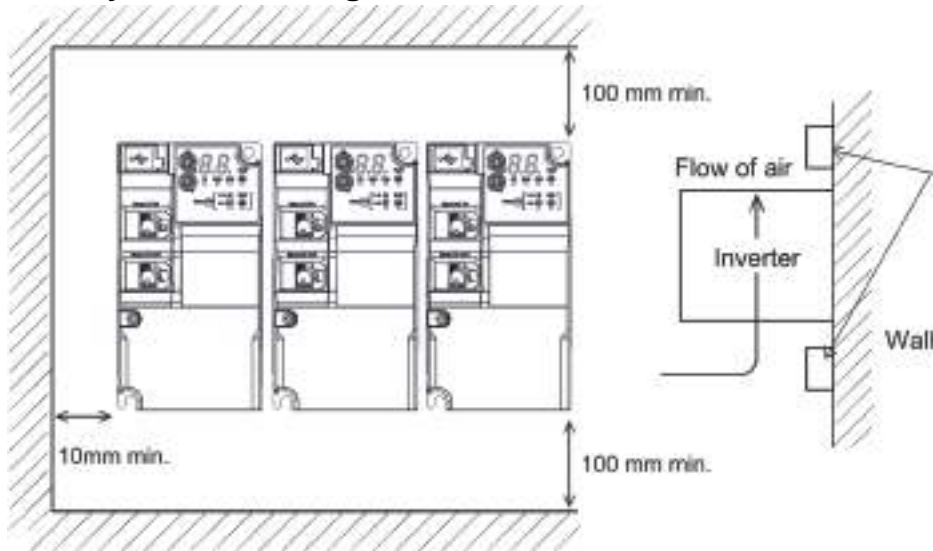

ADD 4 mm gap between drives (Side by side reduces by 10 °C ambient temperature specifications)

Drive watt loss

Max motor capacity	200 V			400 V		
	Loss at 0 % load [W]	Loss at 100 % load of the rated current [W]	Efficiency at 100 % load [W]	Loss at 0 % load [W]	Loss at 100 % load of the rated current [W]	Efficiency at 100 % load [W]
0.2	10	22	90	-		
0.4	10	30	93	10	35	92
0.75	12 (10) <sup>*1</sup>	48	94	10	56	93
1.5	12	79	95	12	96	94
2.2	12	104	95.5	12	116	95
3	-			12	125	96
3.7	12	154	96	-		
4	-			12	167	96
5.5	14	229	96	14	229	96
7.5	14	313	96	14	296	96.2
11	19	458	96	19	411	96.4
15	19	625	96	19	528	96.5

\*1: The value in parentheses ( ) I for single phase 200 V class inverter



# Ordering information

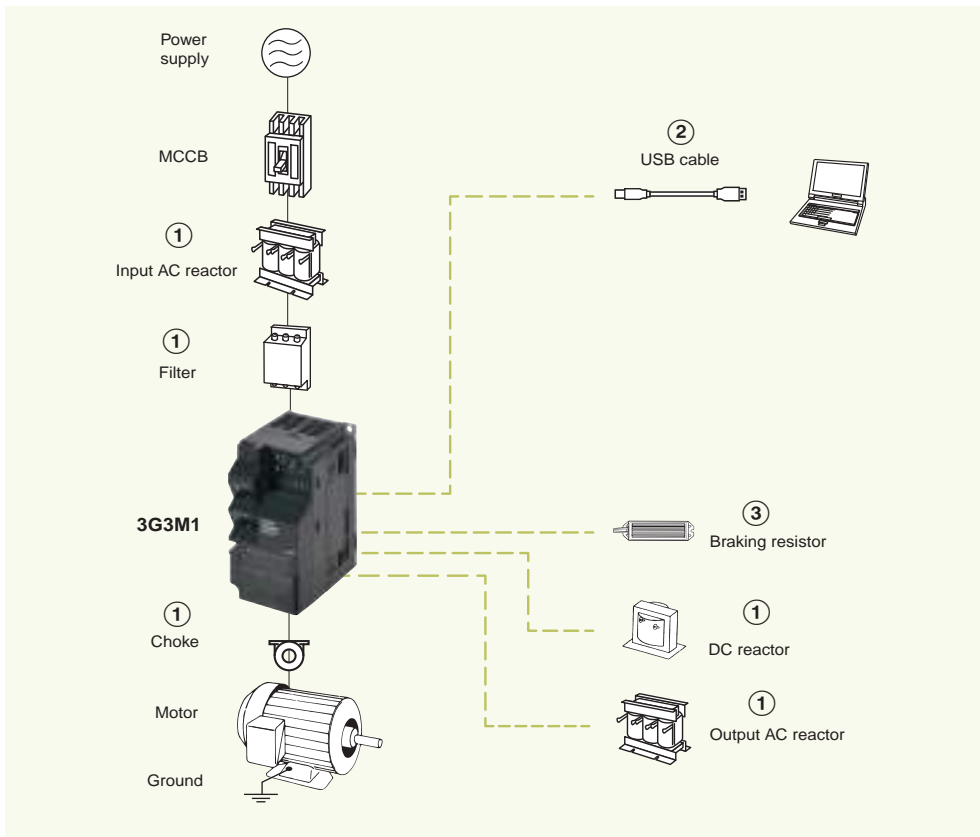

M1 drive

Voltage	Specifications								Model 3G3M1-□
	ND		HD		HND		HHD		
	Max motor (kW)	Rated current (A)	Max motor (KW)	Rated current (A)	Max motor (kW)	Rated current (A)	Max motor (kW)	Rated current (A)	
Single phase 200 V					0.4	1.9	0.2	1.6	AB002-ECT
					0.55	3.5	0.4	3.0	AB004-ECT
					1.1	5.3	0.75	5.0	AB007-ECT
					2.2	9.6	1.5	8.0	AB015-ECT
					3	11.2	2.2	11	AB022-ECT
					-		3.7	17.5	AB037-ECT
3 phase 200 V					0.4	2.0	0.2	1.6	A2002-ECT
					0.75	3.5	0.4	3.0	A2004-ECT
					1.1	6.0	0.75	5.0	A2007-ECT
					2.2	9.6	1.5	8.0	A2015-ECT
					3.0	12	2.2	11	A2022-ECT
					5.5	19.6	3.7	17.5	A2037-ECT
					7.5	30	5.5	25	A2055-ECT
					11	40	7.5	33	A2075-ECT
					15	56	11	47	A2110-ECT
					18.5	69	15	60	A2150-ECT
3 phase 400 V	0.75	2.1	0.75	1.8	0.75	2.1	0.4	1.8	A4004-ECT
	1.5	4.1	1.1	3.4	1.1	4.1	0.75	3.4	A4007-ECT
	2.2	5.5	2.2	5	2.2	5.5	1.5	4.8	A4015-ECT
	3.0	6.9	3.0	6.3	3.0	6.9	2.2	5.5	A4022-ECT
	4	9.2	4	8.8	4	8.8	3	7.2	A4030-ECT
	5.5	12	5.5	11.1	5.5	11.1	4	9.2	A4040-ECT
	11	21.5	7.5	17.5	7.5	17.5	5.5	14.8	A4055-ECT
	15	28.5	11	23	11	23	7.5	18	A4075-ECT
	18.5	37	15	31	15	31	11	24	A4110-ECT
	22	44	18.5	38	18.5	38	15	31	A4150-ECT
	30	59	22	45	22	45	18.5	39	A4185-ECT
	37	72	30	60	30	60	22	45	A4220-ECT

## ① Line filters

Drive		Standard line filter		Low leakage line filter	
Voltage	Model 3G3M1-A□-ECT	Reference	Current (A)	Reference	Current (A)
Single-phase 200 V	B002 to B007	AX-FIC1014-SE	13.8	AX-FIC1014-SE-LL	13.8
	B015	AX-FIC1021-SE	20.2	AX-FIC1021-SE-LL	20.2
	B022	AX-FIC1026-SE	26	AX-FIC1026-SE-LL	26
	B037	AX-FIC1045-SE	45.4	AX-FIC1045-SE-LL	45.4
Three-phase 200 V	2001/2002	AX-FIC4004-SE	3.9	AX-FIC4004-SE-LL	3.9
	2004/2007	AX-FIC4011-SE	11.3	AX-FIC4011-SE-LL	11.3
	2015	AX-FIC4017-SE	16.8	AX-FIC4017-SE-LL	16.8
	2022/2037/2055	AX-FIC4044-SE	43.8	AX-FIC4044-SE-LL	43.8
	2075/2110	AX-FIC4061-SE	60.6	AX-FIC4061-SE-LL	60.6
	2150 2185	–	Contact Omron for details	–	
Three-phase 400 V	4004/4007	AX-FIC4004-SE	3.9	AX-FIC4004-SE-LL	3.9
	4015/4022	AX-FIC4011-SE	11.3	AX-FIC4011-SE-LL	11.3
	4030/4040	AX-FIC4017-SE	16.8	AX-FIC4017-SE-LL	16.8
	4055/4075	AX-FIC4044-SE	43.8 <sup>*1</sup>	AX-FIC4044-SE-LL	43.8 <sup>*1</sup>
	4110/4150	AX-FIC4061-SE	60.6 <sup>*1</sup>	AX-FIC4061-SE-LL	60.6 <sup>*1</sup>
	4185/4220	AX-FIC4095-SE	94.3 <sup>*1</sup>	AX-FIC4095-SE-LL	94.3 <sup>*1</sup>

\*1: Current at 40°C

**Note:** 200 V Three-phase filters are not footprint. (Smaller filter could be used in some cases if DC reactor is used).

## ① DC reactors

400 V Three phase						200 V Single phase					
3G3M1	Rating	Reference	mH	A	Losses W	3G3M1	Rating	Reference	mH	A	Losses W
4004-ECT	HHD	AX-RC43000020-DE	43.0	2.0	17	B002-ECT	HHD	AX-RC10700032-DE	10.7	3.2	14
	HD/HND	AX-RC27000030-DE	27.0	3.0	21		HND	AX-RC06750061-DE	6.75	6.1	18
	ND	AX-RC27000030-DE	27.0	3.0	21	B004-ECT	HHD	AX-RC06750061-DE	6.75	6.1	18
4007-ECT	HHD	AX-RC27000030-DE	27.0	3.0	21		HND	AX-RC03510093-DE	3.51	9.3	20
	HD/HND	AX-RC14000047-DE	14.0	4.7	25	B007-ECT	HHD	AX-RC03510093-DE	3.51	9.3	20
	ND	AX-RC14000047-DE	14.0	4.7	25		HND	AX-RC02510138-DE	2.51	13.8	24
4015-ECT	HHD	AX-RC14000047-DE	14.0	4.7	25	B015-ECT	HHD	AX-RC02510138-DE	2.51	13.8	24
	HD/HND	AX-RC10100069-DE	10.1	6.9	28		HND	AX-RC01600223-DE	1.60	22.3	30
	ND	AX-RC10100069-DE	10.1	6.9	28	B022-ECT	HHD	AX-RC01600223-DE	1.60	22.3	30
4022-ECT	HHD	AX-RC10100069-DE	10.1	6.9	28		HND	AX-RC01110309-DE	1.11	30.9	40
	HD/HND	AX-RC06400116-DE	6.4	11.6	32	B037-ECT	HHD	AX-RC01110309-DE	1.11	30.9	40
	ND	AX-RC06400116-DE	6.4	11.6	32		HND	–			
4030-ECT	HHD	AX-RC06400116-DE	6.4	11.6	32	<b>200 V Three phase</b>					
	HD/HND	AX-RC06400116-DE	6.4	11.6	32	2002-ECT	HHD	AX-RC21400016-DE	21.4	1.6	7
	ND	AX-RC06400116-DE	6.4	11.6	32		HND	AX-RC10700032-DE	10.7	3.2	14
4040-ECT	HHD	AX-RC06400116-DE	6.4	11.6	32	2004-ECT	HHD	AX-RC10700032-DE	10.7	3.2	14
	HD/HND	AX-RC04410167-DE	4.4	16.7	40		HND	AX-RC06750061-DE	6.75	6.1	18
	ND	AX-RC04410167-DE	4.4	16.7	40	2007-ECT	HHD	AX-RC06750061-DE	6.75	6.1	18
4055-ECT	HHD	AX-RC04410167-DE	4.4	16.7	40		HND	AX-RC03510093-DE	3.51	9.3	20
	HD/HND	AX-RC03350219-DE	3.35	21.9	47	2015-ECT	HHD	AX-RC03510093-DE	3.51	9.3	20
	ND	AX-RC02330307-DE	2.33	30.7	63		HND	AX-RC02510138-DE	2.51	13.8	24
4075-ECT	HHD	AX-RC03350219-DE	3.35	21.9	47	2022-ECT	HHD	AX-RC02510138-DE	2.51	13.8	24
	HD/HND	AX-RC02330307-DE	2.33	30.7	63		HND	AX-RC01600223-DE	1.60	22.3	30
	ND	AX-RC01750430-DE	1.75	43.0	77	2037-ECT	HHD	AX-RC01600223-DE	1.60	22.3	30
4110-ECT	HHD	AX-RC02330307-DE	2.33	30.7	63		HND	AX-RC01110309-DE	1.11	30.9	40
	HD/HND	AX-RC01750430-DE	1.75	43.0	77	2055-ECT	HHD	AX-RC01110309-DE	1.11	30.9	40
	ND	AX-RC01750430-DE	1.75	43.0	77		HND	AX-RC00840437-DE	0.84	43.7	46
4150-ECT	HHD	AX-RC01750430-DE	1.75	43.0	77	2075-ECT	HHD	AX-RC00840437-DE	0.84	43.7	46
	HD/HND	AX-RC01750430-DE	1.75	43.0	77		HND	AX-RC00590614-DE	0.59	61.4	60
	ND	AX-RC01200644-DE	1.20	64.4	99	2110-ECT	HHD	AX-RC00590614-DE	0.59	61.4	60
4185-ECT	HHD	AX-RC01750430-DE	1.75	43.0	77		HND	AX-RC00440859-DE	0.44	85.9	75
	HD/HND	AX-RC01200644-DE	1.20	64.4	99	2150-ECT	HHD	AX-RC00440859-DE	0.44	85.9	75
	ND	AX-RC00920797-DE	0.92	79.7	111		HND	AX-RC00440859-DE	0.44	85.9	75
4220-ECT	HHD	AX-RC01200644-DE	1.20	64.4	99	2185-ECT	HHD	AX-RC00440859-DE	0.44	85.9	75
	HD/HND	AX-RC00920797-DE	0.92	79.7	111		HND	AX-RC00301275-DE	0.3	127.5	107
	ND	AX-RC00920797-DE*	0.92	79.7	111	–					

① Input AC reactor (Considering DC reactor is installed)

400 V Three phase						200 V Single phase					
3G3M1	Rating	Reference	mH	A	Losses	3G3M1	Rating	Reference	mH	A	Losses
4004-ECT	HHD	AX-RAI07700042-DE	7.7	4.2	32	B002-ECT	HHD	AX-RAI02000070-DE	2.0	7.0	14
	HD/HND	AX-RAI07700042-DE	7.7	4.2	32		HND	AX-RAI02000070-DE	2.0	7.0	14
	ND	AX-RAI07700042-DE	7.7	4.2	32		B004-ECT	HHD	AX-RAI02000070-DE	2.0	7.0
4007-ECT	HHD	AX-RAI03700040-DE	3.7	4.0	18	HND		AX-RAI02000070-DE	2.0	7.0	14
	HD/HND	AX-RAI03700040-DE	3.7	4.0	18	B007-ECT		HHD	AX-RAI01700140-DE	1.7	14.0
	ND	AX-RAI03700040-DE	3.7	4.0	18		HND	AX-RAI01700140-DE	1.7	14.0	22
4015-ECT	HHD	AX-RAI02800080-DE	2.8	8.0	31		B015-ECT	HHD	AX-RAI01700140-DE	1.7	14.0
	HD/HND	AX-RAI02800080-DE	2.8	8.0	31	HND		AX-RAI01700140-DE	1.7	14.0	22
	ND	AX-RAI02800080-DE	2.8	8.0	31	B022-ECT		HHD	AX-RAI01200200-DE	1.2	20.0
4022-ECT	HHD	AX-RAI01630090-DE	1.63	9.0	40		HND	AX-RAI00630240-DE	0.63	24.0	26
	HD/HND	AX-RAI01630090-DE	1.63	9.0	40		B037-ECT	HHD	AX-RAI00210330-DE*1	0.21	33.0
	ND	AX-RAI01630090-DE	1.63	9.0	40	-					
4030-ECT	HHD	AX-RAI01630090-DE	1.63	9.0	40	200 V Three phase					
	HD/HND	AX-RAI01630090-DE	1.63	9.0	40	2002-ECT	HHD	AX-RAI02920030-DE	2.92	3.0	8
	ND	AX-RAI01630090-DE	1.63	9.0	40		HND	AX-RAI02920030-DE	2.92	3.0	8
4040-ECT	HHD	AX-RAI01300170-DE	1.30	17.0	67	2004-ECT	HHD	AX-RAI01570050-DE	1.57	5.0	12
	HD/HND	AX-RAI01300170-DE	1.30	17.0	67		HND	AX-RAI01570050-DE	1.57	5.0	12
	ND	AX-RAI01300170-DE	1.30	17.0	67	2007-ECT	HHD	AX-RAI01570050-DE	1.57	5.0	12
4055-ECT	HHD	AX-RAI00810180-DE	0.81	18.0	79		HND	AX-RAI00940080-DE	0.94	8.0	18
	HD/HND	AX-RAI00810180-DE	0.81	18.0	79	2015-ECT	HHD	AX-RAI00940080-DE	0.94	8.0	18
	ND	AX-RAI00740335-DE	0.74	33.5	79		HND	AX-RAI00670110-DE	0.67	11.0	24
4075-ECT	HHD	AX-RAI00810180-DE	0.81	18.0	79	2022-ECT	HHD	AX-RAI00670110-DE	0.67	11.0	24
	HD/HND	AX-RAI00740335-DE	0.74	33.5	240		HND	AX-RAI00450170-DE	0.45	17.0	39
	ND	AX-RAI00440300-DE	0.44	30.0	119	2037-ECT	HHD	AX-RAI00450170-DE	0.45	17.0	39
4110-ECT	HHD	AX-RAI00740335-DE	0.74	33.5	240		HND	AX-RAI00290250-DE	0.29	25.0	54
	HD/HND	AX-RAI00440300-DE	0.44	30.0	119	2055-ECT	HHD	AX-RAI00290250-DE	0.29	25.0	54
	ND	AX-RAI00360500-DE	0.36	50.0	85		HND	AX-RAI00210330-DE	0.21	33.0	69
4150-ECT	HHD	AX-RAI00440300-DE	0.44	30.0	119	2075-ECT	HHD	AX-RAI00210330-DE	0.21	33.0	69
	HD/HND	AX-RAI00360500-DE	0.36	50.0	85		HND	AX-RAI00180670-DE	0.18	67.0	71
	ND	AX-RAI00300450-DE	0.30	45.0	182	2110-ECT	HHD	AX-RAI00180670-DE	0.18	67.0	71
4185-ECT	HHD	AX-RAI00360500-DE	0.36	50.0	85		HND	AX-RAI00110600-DE	0.11	60.0	119
	HD/HND	AX-RAI00300450-DE	0.30	45.0	182	2150-ECT	HHD	AX-RAI00110600-DE	0.11	60.0	119
	ND	AX-RAI00191150-DE	0.19	115.0	177		HND	AX-RAI00091000-DE	0.09	100.0	84
4220-ECT	HHD	AX-RAI00290780-DE	0.29	78.0	116	2185-ECT	HHD	AX-RAI00091000-DE	0.09	100.0	84
	HD/HND	AX-RAI00191150-DE	0.19	115.0	177		HND	AX-RAI00076870-DE	0.07	87.0	173
	ND	AX-RAI00191150-DE	0.19	115.0	177	-					

Note: This table corresponds with ND/HND rating. When using HD in some case it could be possible to select a smaller size.

① Output AC reactors

200 V					Three-phase 400 V					
3G3M1-A□-ECT	Rating	Output AC reactor	mH	A	3G3M1-A□-ECT	Rating	Output AC reactor	mH	A	
B002/2002	HHD	AX-RAO11500026-DE	11.5	2.6	4004	HHD	AX-RAO16300038-DE	16.3	3.8	
	HND	AX-RAO11500026-DE	11.5	2.6		HD/HND	AX-RAO16300038-DE	16.3	3.8	
B004/2004	HHD	AX-RAO07600042-DE	7.6	4.2		ND	AX-RAO16300038-DE	16.3	3.8	
	HND	AX-RAO07600042-DE	7.6	4.2		HHD	AX-RAO16300038-DE	16.3	3.8	
B007/2007	HHD	AX-RAO04100075-DE	4.1	7.5		4007	HD/HND	AX-RAO11800053-DE	11.8	5.3
	HND	AX-RAO04100075-DE	4.1	7.5			ND	AX-RAO11800053-DE	11.8	5.3
B015/2015	HHD	AX-RAO03000105-DE	3.0	10.5	4015/4022		HHD	AX-RAO11800053-DE	11.8	5.3
	HND	AX-RAO03000105-DE	3.0	10.5		HD/HND	AX-RAO07300080-DE	7.3	8.0	
B022/2022	HHD	AX-RAO01830160-DE	1.8	16.0		ND	AX-RAO07300080-DE	7.3	8.0	
	HND	AX-RAO01830160-DE	1.8	16.0	4030	HHD	AX-RAO04600110-DE	4.6	11.0	
B037/2037	HHD	AX-RAO01150220-DE	1.15	22.0		HD/HND	AX-RAO04600110-DE	4.6	11.0	
	HND	AX-RAO01150220-DE	1.15	22.0		ND	AX-RAO04600110-DE	4.6	11.0	
2055	HHD	AX-RAO00950320-DE	0.95	32.0	4040	HHD	AX-RAO04600110-DE	4.6	11.0	
	HND	AX-RAO00950320-DE	0.95	32.0		HD/HND	AX-RAO03600160-DE	3.6	16.0	
2075	HHD	AX-RAO00630430-DE	0.63	43.0		ND	AX-RAO03600160-DE	3.6	16.0	
	HND	AX-RAO00630430-DE	0.63	43.0	4055	HHD	AX-RAO03600160-DE	3.6	16.0	
2110	HHD	AX-RAO00490640-DE	0.49	64.0		HD/HND	AX-RAO02500220-DE	2.5	22.0	
	HND	AX-RAO00490640-DE	0.49	64.0		ND	AX-RAO02500220-DE	2.5	22.0	
2150	HHD	AX-RAO00490640-DE	0.49	64.0	4075	HHD	AX-RAO02500220-DE	2.5	22.0	
	HND	AX-RAO00390800-DE	0.39	80.0		HD/HND	AX-RAO02000320-DE	0.20	32.0	
2185	HHD	AX-RAO00390800-DE	0.39	80.0		ND	AX-RAO02000320-DE	0.20	32.0	
	HND	AX-RAO00330950-DE	0.33	95.0	4110	HHD	AX-RAO02000320-DE	0.20	32.0	
-						HD/HND	AX-RAO02000320-DE	0.20	32.0	
						ND	AX-RAO01650400-DE	0.16	40.0	
					4150	HHD	AX-RAO01650400-DE	0.16	40.0	
						HD/HND	AX-RAO01650400-DE	0.16	40.0	
						ND	AX-RAO01300480-DE	0.13	48.0	
					4185	HHD	AX-RAO01300480-DE	0.13	48.0	
						HD/HND	AX-RAO01300480-DE	0.13	48.0	
						ND	AX-RAO00800750-DE	0.08	75.0	
					4220	HHD	AX-RAO01300480-DE	0.13	48.0	
						HD/HND	AX-RAO00800750-DE	0.08	75.0	
						ND	AX-RAO00800750-DE	0.08	75.0	

Note: This table corresponds with ND/HND rating. When using HD in some case it could be possible to select a smaller size.

## ① Chokes

Diameter	Description	Model
21	For 2.2 KW motors or below	AX-FER2102-PE
28	For 15 KW motors or below	AX-FER2815-PE
50	For 45 KW motors or below	AX-FER5045-PE

## ② Accessories

Description	Functions	Model
USB cable	Use a commercially available USB cable that is double-shielded, gold-plated and supports USB 2.0. The Micro B type USB cable can be used.	–

## Software tools

Description	Functions	Number licenses	Media	Model
Sysmac Studio Standard Edition Ver.1.XX	The Sysmac Studio is the software that provides an integrated environment for setting, programming, debugging and maintenance of machine automation controllers including NJ/NX-series CPU Units, NY-series Industrial PC, EtherCAT Slaves, and HMI. Sysmac Studio runs on the following OS: Windows 7 (32-bit/64-bit version)/Windows 8.1 (32-bit/64-bit version) Windows 10 (32-bit/64-bit version)/Windows 11 (64-bit version) This software provides functions of the Vision Edition. Refer to your local OMRON website for details such as supported models and functions.	(Media only)	Sysmac Studio (32 bit) DVD	SYSMAC-SE200D
		(Media only)	Sysmac Studio (64 bit) DVD	SYSMAC-SE200D-64
		1 license	–	SYSMAC-SE201L
Sysmac Studio Drive Edition Ver.1.XX	Sysmac Studio Drive Edition is a limited license that provides selected functions required for 1S-series Servo, G5-series Servo and M1 Series Inverter System settings. Because this product is a license only, you need the Sysmac Studio Standard Edition DVD media to install it.	1 license	–	SYSMAC-DE001L

③ Braking resistor

Voltage	3G3M1-A□-ECT	Conn. min. resistance	Resistor proposal fast stop (10s not cyclic)			Braking resistor (3% ED, 10 sec)			Braking resistor (10% ED, 10sec)		
			Model	Specifications		Model	Specifications		Model	Specifications	
1 phase 200 V	B002	100 Ω	AX-REM00K1100-IE	100 W	100 Ω	AX-REM00K1100-IE	100 W	100 Ω	AX-REM00K2100-IE	200 W	100 Ω
	B004		AX-REM00K1100-IE	100 W	100 Ω	AX-REM00K1100-IE	100 W	100 Ω	AX-REM00K2100-IE	200 W	100 Ω
	B007		AX-REM00K1100-IE	100 W	100 Ω	AX-REM00K1100-IE	100 W	100 Ω	AX-REM00K2100-IE	200 W	100 Ω
	B015	40 Ω	AX-REM00K2040-IE	200 W	40 Ω	AX-REM00K2050-IE	200 W	50 Ω	AX-REM00K4050-IE	400 W	50 Ω
	B022		AX-REM00K2040-IE	200 W	40 Ω	AX-REM00K2050-IE	200 W	50 Ω	AX-REM00K4050-IE	400 W	50 Ω
	B037		AX-REM00K4040-IE	400 W	40 Ω	AX-REM00K4050-IE	400 W	50 Ω	AX-REM00K6050-IE	600 W	50 Ω
3 phase 400 V	4004	200 Ω	AX-REM00K1200-IE	100 W	200 Ω	AX-REM00K1200-IE	100 W	200 Ω	AX-REM00K4200-IE	400 W	200 Ω
	4007		AX-REM00K1200-IE	100 W	200 Ω	AX-REM00K1200-IE	100 W	200 Ω	AX-REM00K4200-IE	400 W	200 Ω
	4015	160 Ω	AX-REM00K3160-IE	300 W	160 Ω	AX-REM00K1200-IE	100 W	200 Ω	AX-REM00K4200-IE	400 W	200 Ω
	4022		AX-REM00K3160-IE	300 W	160 Ω	AX-REM00K1200-IE	100 W	200 Ω	AX-REM00K4200-IE	400 W	200 Ω
	4030	130 Ω	AX-REM00K4130-IE	400 W	130 Ω	AX-REM00K2150-IE	200 W	150 Ω	AX-REM00K6150-IE	600 W	150 Ω
	4040		AX-REM00K4130-IE	400 W	130 Ω	AX-REM00K2150-IE	200 W	150 Ω	AX-REM00K6150-IE	600 W	150 Ω
	4055	80 Ω	AX-REM00K6080-IE	600 W	80 Ω	AX-REM00K3100-IE	300 W	100 Ω	AX-REM00K9100-IE	900 W	100 Ω
	4075	60 Ω	AX-REM00K9060-IE	900 W	60 Ω	AX-REM00K4070-IE	400 W	70 Ω	AX-REM01K3070-IE	1300 W	70 Ω
	4110	40 Ω	AX-REM00K9040-IE	900 W	40 Ω	AX-REM00K4050-IE	400 W	50 Ω	AX-REM01K9050-IE	1900 W	50 Ω
	4150	34.4 Ω	AX-REM00K9040-IE	900 W	40 Ω	AX-REM00K4050-IE	400 W	50 Ω	AX-REM01K9050-IE	1900 W	50 Ω
	4185	16 Ω	AX-REM01K9017-IE	1900 W	17 Ω	AX-REM01K1020-IE	1100 W	20 Ω	AX-REM03K5020-IE	3500 W	20 Ω
	4220		AX-REM01K9017-IE	1900 W	17 Ω	AX-REM01K1020-IE	1100 W	20 Ω	AX-REM03K5020-IE	3500 W	20 Ω
3 phase 200 V	2002	100 Ω	AX-REM00K1100-IE	100 W	100 Ω	AX-REM00K1100-IE	100 W	100 Ω	AX-REM00K2100-IE	200 W	100 Ω
	2004		AX-REM00K1100-IE	100 W	100 Ω	AX-REM00K1100-IE	100 W	100 Ω	AX-REM00K2100-IE	200 W	100 Ω
	2007		AX-REM00K1100-IE	100 W	100 Ω	AX-REM00K1100-IE	100 W	100 Ω	AX-REM00K2100-IE	200 W	100 Ω
	2015	40 Ω	AX-REM00K2040-IE	200 W	40 Ω	AX-REM00K2050-IE	200 W	50 Ω	AX-REM00K4050-IE	400 W	50 Ω
	2022		AX-REM00K2040-IE	200 W	40 Ω	AX-REM00K2050-IE	200 W	50 Ω	AX-REM00K4050-IE	400 W	50 Ω
	2037	33 Ω	AX-REM00K4035-IE	400 W	35 Ω	AX-REM00K2040-IE	200 W	40 Ω	AX-REM00K4040-IE	400 W	40 Ω
	2055	20 Ω	AX-REM00K4020-IE	400 W	20 Ω	AX-REM00K3025-IE	300 W	25 Ω	AX-REM00K6030-IE	600 W	30 Ω
	2075	15 Ω	AX-REM00K6015-IE	600 W	15 Ω	AX-REM00K4020-IE	400 W	20 Ω	AX-REM00K9020-IE	900 W	20 Ω
	2110	10 Ω	AX-REM00K9010-IE	900 W	10 Ω	AX-REM00K6015-IE	600 W	15 Ω	AX-REM001K1015-IE	1100 W	15 Ω
	2150	8.6 Ω	AX-REM00K9010-IE	900 W	10 Ω	AX-REM00K6015-IE	600 W	15 Ω	AX-REM001K1015-IE	1100 W	15 Ω
2185	4 Ω	AX-REM02K1004-IE	2000 W	4 Ω	AX-REM00K9006-IE	900 W	6 Ω	AX-REM03K5006-IE	3500 W	6 Ω	



ALL DIMENSIONS SHOWN ARE IN MILLIMETERS.  
To convert millimeters into inches, multiply by 0.03937. To convert grams into ounces, multiply by 0.03527.